



PLATE MAGNETS

Plate-based magnetic separators available for installation in chutes and use with all materials.

- Optional grain face for abrasive materials.
- Ideal for 30° to 60° angles.
- 300 series Stainless Steel construction.
- Tapered Step Face to prevent product wipe off is standard
- Ceramic and High-Intensity Rare Earth magnets are available
- All finishes available.



USDA, AMS-accepted Plate Magnet



Tapered Step Plate Magnet

How to Select and Order Bunting Plate Magnets

The following steps will help you select and order a Plate Magnet that's right for your chute or spouting application. As you go from step to step, jot down the selections you make: The eight-part Plate Magnet Model Number is made up of coded entries for your selections. The first part of the Model Number is PM for Plate Magnet. The second part is a code for the magnet that meets your product flow rate needs. The third part is a two-digit entry for the width you select. The remaining parts of the Plate Magnet Model Number are explained below, along with the selection steps. Here's a sample Model Number to show you what a complete one looks like.

grain face for abrasive materials.

PM	C65	24	P	M	H	U	S
----	-----	----	---	---	---	---	---

If you have any questions or want additional guidance in making your selections, call us at +44 (0)1442 875 081 or e-mail: sales@buntingeurope.com. We'll be glad to help you make the right choices.



PLATE MAGNETS

Step 1:

Estimate the maximum flow rate through your chute in cubic feet per hour. Then use the Ceramic or Rare Earth Adjustments tables to adjust this flow capacity for the size of tramp iron you encounter and your chute angle. If the magnet will be more than two feet from the feed opening of a chute, increase required capacity by 10% for each additional foot. If you intend to mount two identical magnets within 6" of each other, reduce the required magnet capacity by 50%. This new figure is your revised maximum flow rate estimate.

Ceramic Plate Adjustments

	35 Degree 35 degree	Chute Angle 45 degree	60 degree
Large Tramp .03 to .24 litre	Use 125% of Capacity	Use Capacity	Use 75% of Capacity
Small Tramp 8 mesh to .8 litre	Use Capacity	Use 75% of Capacity	Use 50% of Capacity
Fine Tramp 8 mesh and less	Use 33% of Capacity	Use 25% of Capacity	Use 12% of Capacity

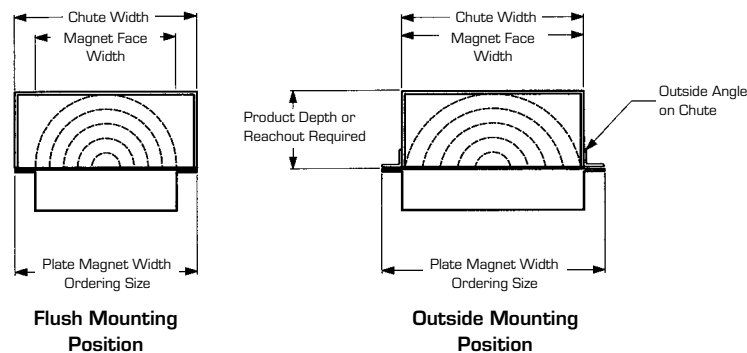
Rare Earth Application Adjustments

	35 Degree 35 degree	Chute Angle 45 degree	60 degree
Large Tramp .03 to .24 litre	Use 125% of Capacity	Use Capacity	Use 75% of Capacity
Small Tramp 8 mesh to .8 litre	Use Capacity	Use 75% of Capacity	Use 50% of Capacity
Fine Tramp 8 mesh and less	Use 40% of Capacity	Use 30% of Capacity	Use 20% of Capacity

Step 2:

Determine the widest Plate Magnet your chute or spouting will accommodate. Because of the mounting flanges, the actual width of the magnet face is 5 cm less than the Plate Magnet's overall width. This can create an area of unprotected product flow. To get maximum protection, consider getting a full-width magnet and using angle-iron mounts as shown in the illustration to the right.

Cross Section of Chute with Plate Magnets Installed





Step 3:

Now that you know what width you want and have a reasonable estimate of flow rate, look over the Plate Magnet Capacities and Weights table to see which magnets are in your ballpark. First find the width that's closest to the width of your chute or spouting, and look across the adjacent row of flow rates for the capacity that's closest to the maximum capacity you've estimated.

Notice that both Ceramic and Neodymium Plate Magnets come with three flow rate capacities for each width. These three strength levels are represented by model numbers. The model numbers (C30, C45, C65 and N35, N50, N65) indicate the vertical reachout of the magnetic field. For example, C45 has a 11 cm reachout; N50 has a 13 cm reachout. Select the reachout that most closely corresponds to the depth of your chute or spouting.

Neodymium magnets cost more than Ceramic, but Neodymium magnets can be from 40% to 60% lighter than Ceramic magnets with similar flow rate capacities. Think about where you will install the magnet, your spouting's ability to carry its weight, and the possible difficulty or danger a heavy magnet might pose to workers. Then make a preliminary choice between Ceramic and Neodymium and write down the model with the capacity and reachout you need plus the width you've chosen before moving on.

Plate Magnet Capacities and Weights

Flow rates in cubic cm/hour. Weights in kg.

Chute Width	Ceramic		Neodymium			
	C30	C45	C65	N35	N50	N65
20	58/8kg	86/16Kg	147/37Kg	57/5Kg	81/10Kg	106/17Kg
25	72/11Kg	109/22Kg	188/49Kg	71/7Kg	102/13Kg	132/23Kg
30	87/14Kg	124/27Kg	228/61Kg	85/8Kg	122/15Kg	158/28Kg
35	101/16Kg	145/32Kg	267/72Kg	100/10Kg	142/19Kg	185/34Kg
41	116/19Kg	163/37Kg	305/84Kg	114/11Kg	163/22Kg	211/39Kg
46	130/21Kg	184/42Kg	342/96Kg	128/13Kg	183/24Kg	238/44Kg
51	144/24Kg	205/48Kg	381/107Kg	142/15Kg	203/28Kg	264/50Kg
56	159/26Kg	226/52Kg	418/119Kg	156/16Kg	224/30Kg	291/55Kg
61	174/29Kg	244/57Kg	456/131Kg	171/18Kg	244/34Kg	317/61Kg
76	217/36Kg	306/73Kg	571/166Kg	213/22Kg	305/43Kg	396/77Kg
91	260/44Kg	363/88Kg	685/200Kg	256/27Kg	366/51Kg	475/93Kg
107	304/51Kg	425/103Kg	796/235kg	298/32Kg	427/60Kg	555/110Kg
122	347/59Kg	485/118Kg	914/271Kg	342/46Kg	488/69Kg	634/126Kg
137	391/66Kg	546/133Kg	1028/306Kg	384/41Kg	549/78Kg	713/142Kg
152	434/74Kg	607/149Kg	1142/341Kg	427/46Kg	610/87Kg	792/159Kg

PM C65 24 P M H U S

For Part 2 of the Model Number enter one of these Magnet codes:

- C30** Ceramic with 8.0 cm reachout
- C45** Ceramic with 11 cm reachout
- C65** Ceramic with 17 cm reachout
- N35** Neo with 9 cm reachout
- N50** Neo with 13 cm reachout
- N65** Neo with 17 cm reachout

PM C65 24 P M H U S

For Part 3 of the Model Number enter the Plate Magnet width you want:

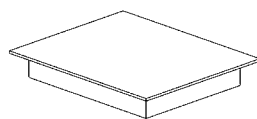
Enter a two-digit number within the 20-cm to 152-cm range.

Flat Face Model is especially recommended for maintaining a sanitary environment. For low-density product applications and inverted installations.

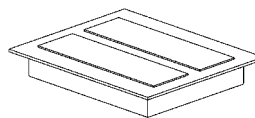


Plate Magnet Face Styles

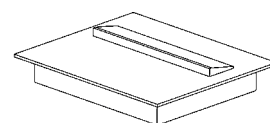
Plate Magnets have stainless steel exteriors and come in three face styles and six magnetic strengths to cover a wide range of applications. All magnetic loads have been redesigned to deliver up to three times the surface holding force while still maintaining the same powerful reach-out. Faces of pole and tapered step models are constructed of 410/416 magnetic stainless steel and especially well suited to holding captured tramp and fines securely in place. Self-cleaning units are available in tapered step and flat face styles.



A. Flat Face Model is especially recommended for maintaining a sanitary environment. For low-density product applications and inverted installations.



B. Pole Face Model features two exposed pole plates to capture and hold contaminants. For low-density product applications.



C. Tapered Step Face Model is specifically designed to hold ferrous debris against its solid tapered step to prevent wash-off of tramp iron and fines even when product flow is rapid. For high-density product applications.

Step 4:

Refer to face style illustrations A, B, and C above. If you plan to select the Manual Self-Cleaning Plate Magnet, choose tapered step or flat face. Otherwise, choose any of the three that will work best for you.

PM C65 24 P M H U S

For Part 4 of the Model Number, enter your Face Style choice: F = Flat Face
P = Pole Face T = Tapered Step Face

Step 5:

The next step is to decide whether or not you want the mounting kit. Illustrations D and E at right show standard plate configuration and what comes with the optional mounting kit.

PM C65 24 P M H U S

For Part 5 of the Model Number, enter your decision about the Mounting Kit.

- X = No Mounting Kit
- M = Mounting Kit with hinges, latch, and hardware

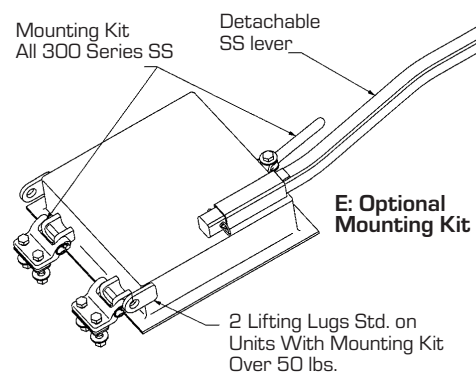
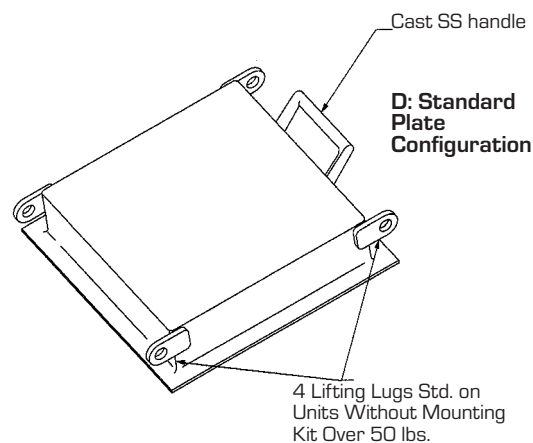
Step 6:

Refer again to the mounting kit and handle illustrations and table of Recommended Accessories. Then make your selection.

PM C65 24 P M H U S

For Part 6 of the Model Number, enter your Handle choice.

- X = No handle, lever, or standard lifting lugs
- N = Standard lifting lugs - but no handle or lever
- H = Cast stainless steel handle
- L = Removable stainless steel lever



Recommended Accessories:

Weight Range	With Hinge			Self Cleaning			Std. Lifting Lug Qty.	
	Handle	Lever	Mech. Assist.	Handle	Lever	Mech. Assist.	With Hinge & Self Cleaning	Without Hinge
0 - 23Kg		X			X	X		0
23 - 45Kg	X	X			X	X	2	4
45 - 90Kg		X	X			X	2	4
Over 90Kg			X			X	4	4